

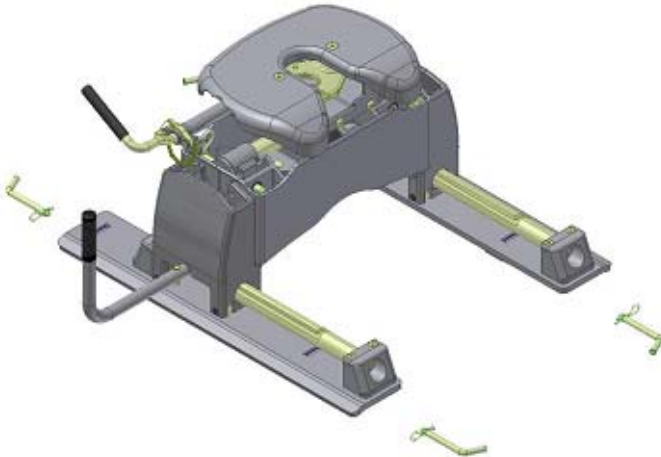

16525/16526

Unpacking – Assembly / Installation



**Installer:** Read and understand this manual. Fully instruct and demonstrate the operation of this 5<sup>th</sup> Wheel Hitch to the End-User. Include the importance of observing all warnings contained herein to include warning labels on 5<sup>th</sup> Wheel Hitch Mid-Section. **Provide this manual in its entirety to the End-User.**

**WARNING:** To avoid serious injury, do not expose hands, body parts, or clothing between the truck and trailer or the truck's bed sides and trailer. Extreme care should be observed to avoid serious injury to self, property, and observers.

**NEVER POSITION YOURSELF OR OTHERS UNDER THE TRAILER'S KINGPIN AREA DURING COUPLING AND UNCOUPLING. SERIOUS INJURY OR DEATH MAY RESULT IF THE WARNING ABOVE IS NOT OBSERVED.**



Unpacking	Page(s) 1, 2
Assembly / Installation	Page(s) 3, 4
Warranty Information	Page(s) 5

---

**WARNING: Read and understand Instructions before use.  
DO NOT EXCEED YOUR VEHICLE'S RATED TOWING  
CAPACITY**

---

**\*\*\*UNPACKING\*\*\***

---

Your Q5 5<sup>th</sup> Wheel has been partially assembled, inspected and tested for fit, function and completeness.

The Q5 5<sup>th</sup> Wheel is an engineered unit that has been designed and tested at the rating of 20,000 lb (Trailer GVW).

Years of trouble-free service may be achieved by adhering to a few simple maintenance points.

**Unpacking:**

The Q5 5<sup>th</sup> Wheel is packed in one reusable box.

Contents will include: **See Page 2**

1. The Q5 5<sup>th</sup> Wheel Head assembled to the Mid-Section.
2. (4) M14 x 2 x 45mm / Grade 8.8 / Yellow Zinc Pilot Hex Bolts  
(4) 14mm x 39mm OD Yellow Zinc Flat Washers  
(4) 14mm Yellow Zinc Lock Washers
3. Q5 5<sup>th</sup> Wheel Manuals:
  - 1) **PA1-16525** - Unpacking – Assembly / Installation
  - 2) **PA2-16525** - Coupling – Uncoupling – Removal – Re-Installation
  - 3) **PA3-16525** - Maintenance Requirements

---

**\*\*\*UNPACKING / Continued\*\*\***

---

**5<sup>th</sup> Wheel Head and Mid-Section**



- (4) M14 x 2 x 45 Pilot Bolts**
- (4) M14 Lock Washers**
- (4) M14 x 39 OD Flat Washers**

**VERY IMPORTANT**

**Torque (4) M14 x 2 x 45 Pilot Bolts to 100 ft-lb.  
Re-torque after initial 500 miles and every 1000  
miles thereafter and prior to each individual use.**

**WARNING: Read and understand Instructions before use.  
DO NOT EXCEED YOUR VEHICLE'S RATED TOWING  
CAPACITY**

---

**\*\*\*ASSEMBLY / INSTALLATION\*\*\***

---

Assembly includes measuring the height requirement for the Q5 5<sup>th</sup> Wheel Head in relation to your trailer ride height at the kingpin box and skid plate. Ideally the trailer should ride as near to level as possible. The Q5 5<sup>th</sup> Wheel is adjustable from 17½ to 21½ inches from the pickup bed to the top of its Skid Plate. Adjustment is attained by adjusting the Mid-Section up or down in relation to the R5 Sides in 2 inch increments.

Typical clearance between the pickup bed rails and the trailer should be a minimum of 5-1/2 inches.

With your trailer on a firm and level surface, set chock blocks in front of and behind the tires. (Do not substitute wood blocks, rocks, etc. for chock blocks.) Extend front trailer lifting jacks, adjust as required to set trailer at or near level.

- 1) Measure from the ground to under the trailer's kingpin box skid plate (or Lube Plate if used). This will be the portion in contact with the Q5 5<sup>th</sup> Wheel's Skid Plate once coupled.
- 2) Measure from the ground to the surface of the pickup bed.
- 3) Subtract **Step 2) from Step 1)**. This value will be near the height requirement for the Q5 5<sup>th</sup> Wheel.

The Q5 5<sup>th</sup> Wheel when assembled at its lowest setting is 17½ inches from the surface of the pickup bed to the top of the Skid Plate. When assembled at its highest setting it is 21½ inches from the pickup bed to the top of the Skid Plate. As mentioned above, the Q5 5<sup>th</sup> Wheel is adjustable in 2 inch increments.

**WARNING: Read and understand Instructions before use.  
DO NOT EXCEED YOUR VEHICLE'S RATED TOWING  
CAPACITY**

---

**\*\*\*ASSEMBLY / INSTALLATION / Continued\*\*\***

---

Once you have determined the height adjustment required for your Q5 5<sup>th</sup> Wheel, assemble the Mid-Section to the R5 sides using the appropriate holes. (See 16500 Instruction Manual page 5 for more information)

**SEE VERY IMPORTANT NOTE ON PAGE 2 OF THIS MANUAL**  
Occasionally, the trailer's kingpin "pin box" will require adjustment to facilitate correct ride height.

**NOTES:**

- 1) The Head Assembly can be removed from the Mid-Section to simplify in the installation of the (4) M14 x 2 x 45mm Pilot Hex Bolts, Lock Washers, and Flat Washers to the R5 Sides.
- 2) See 16500 R5 Instruction Manual for Installation Instructions.

**WARNING: Read and understand Instructions before use.  
DO NOT EXCEED YOUR VEHICLE'S RATED TOWING  
CAPACITY**

---

**\*\*\* Limited 7 Year Warranty \*\*\***

---

CURT Manufacturing Incorporated warrants, to the original purchaser, its products to be free from defect workmanship under normal use and service, ordinary wear and tear excepted for as long as product is owned by the original purchaser.

**Limitations of the Warranty**

CURT Manufacturing Incorporated's obligation under this warranty is limited to repair or replacement, at its option. CURT Manufacturing Incorporated shall not be liable for the loss of or use of vehicles, cost of removal and /or installation, loss of time, inconvenience, rental of vehicles, loss or damage to personal property, expenses such as telephone, lodging, gasoline, towing, or any incidental or consequential damages. CURT Manufacturing Incorporated will examine the returned product. If the defect is covered under the warranty, CURT Manufacturing will repair the item or replace it at that time. Alterations or misuse of the items will not be covered under the warranty.

Some states do not allow the exclusion or limitation of incidental or consequential damages. So the above limitation or exclusion may not apply to you.

This warranty gives you specific legal rights and you may also have other rights, which vary, from state to state.

**Obligations of Purchaser/Consumer**

The following steps need to be followed completely.

1. The purchaser/consumer must present proof of purchase of the defective CURT product to the headquarters of CURT Manufacturing Incorporated. Toll Free Number: 1-877-CURTMFG.
2. The purchaser/consumer must pay all handling charges and shipping charges incurred by the defective products to CURT Manufacturing Incorporated and for delivery of the replacement products by CURT Manufacturing Incorporated to the purchaser/consumer.