

December 2006

INSTALLATION, OPERATION & MAINTENANCE INSTRUCTIONS

MODEL NO. 70750

Please be sure that this document is given to the end user of this product.
This contains many important items relating to the proper usage of this product.

IMPORTANT NOTICE

This is an RV 5th wheel hitch. Use of this hitch for COMMERCIAL trailer towing will limit the hitches warranty to 1 year

COMPLETE PARTS LIST

| Part | Description | Quantity |
|-------------|---------------------------------|-----------------|
| 1. | 2633-05 Hitch Assembly | (1) |
| 2. | 3321-02 Latch Handle Assembly | (1) |
| 3. | 3181-02 Cross Member Assembly | (1) |
| 4. | 2704-01 Pivot Pin Assembly | (1) |
| 5. | 3185-06 Upright Assembly | (2) |
| 6. | 2703-09 Safety Pin | (1) |
| 7. | 2707-01 1-1/2-12 Slotted Nut | (1) |
| 8. | 3590-02 1/4-20 x 1-1/2 Hex Bolt | (1) |
| 9. | 2278-05 1/4-20 Flange Locknut | (1) |
| 10. | 1557-01 Rail Hitch Pin | (4) |
| 11. | 1335-03 Hair Pin | (4) |
| 12. | 2953-03 1/2-13 x 4-1/2 Hex Bolt | (4) |
| 13. | 1888-03 1/2 Flatwasher | (4) |
| 14. | 1880-03 1/2 Lockwasher | (4) |
| 15. | 1862-03 1/2-13 Hex Nut | (4) |

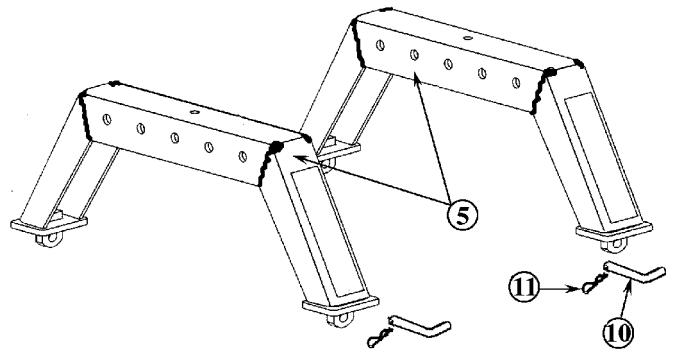
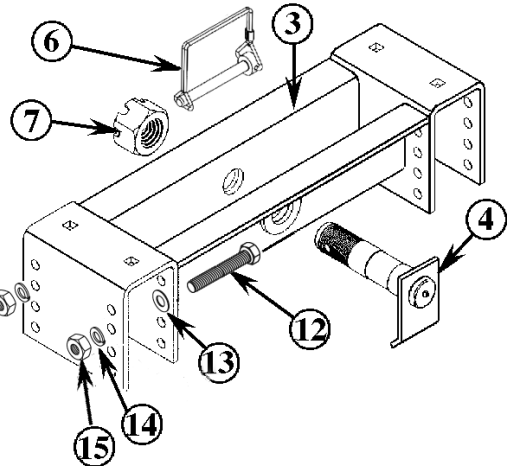
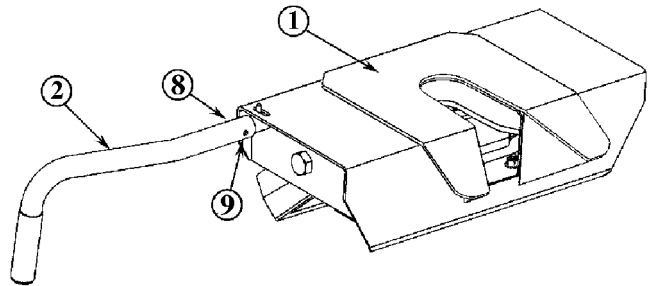

25,000 Maximum Trailer Weight
6,250 Vertical Load Weight

BEFORE BEGINNING INSTALLATION:

Be sure that the loaded trailer weight does not exceed 20,000 lbs. or the vertical load rating does not exceed 5000 lbs.

Be sure that the weight of the loaded trailer does not exceed the truck manufacturers trailer towing or payload capacities.

Use only a 2" king pin with this 5th wheel hitch.

The installed position of the 5th wheel hitch is critical relative to the distance from the cab so that the front of the trailer does not make contact with the cab when turning. On most applications, the distance from the back of the truck cab to the center of the trailer king pin should be 4" greater than 1/2 the width of the trailer.

INSTALLATION INSTRUCTIONS

1. The 5th wheel hitch is packaged in two cartons. The 70580 bed rails and custom install kits, are separate items and are not included with the hitch. Unpack all parts and compare them with the illustrated packing list and installation instructions.
2. Place the two bed rails across the truck bed between the wheel wells. Position the uprights #5 between the bed rails so that the tab in the base upright will fit into the slots in the ends of the bed rails. Secure the uprights in place with the rail hitch pins #10 and hair pins #11.
3. Go to the bed rail and custom install bracket kit instructions, to install the bed rails.
4. Determine the height of the head assembly. This height should be set so that there is 5"-6" minimum clearance between the bottom of the trailer overhang and the top of the truck box. More clearance may be needed if travel over uneven roads is expected. Bolt the cross member assembly #3 between the uprights at the correct height. Tighten all 1/2" bolts to 75 ft. lbs. torque. If pin placement in base rail is tight, it may be necessary to place one of the 1/2 Flatwashers #13 between the cross member and the upright at each attachment bolt. See Illustration 4.
5. Before attaching the yoke on head assembly #1 to the cross member #3, place grease on the outer flat surface of the center pivot pin hole in the yoke. Place the head assembly into channel in cross member #3. Align hole in yoke with hole in cross member and secure with pivot pin #4 and large slotted nut #7. Check the height of the hitch head to be certain that there is the required 5" to 6" minimum clearance between the bottom of the trailer overhang and the top of the truck box. Make any adjustments as needed to obtain this clearance.
6. Attach the handle assembly #2 on the rod located on the left side of the hitch assembly #1. Align holes in handle with holes in rod and bolt in place with the 1/4" hex bolt #8 and the 1/4" flange locknut #9.

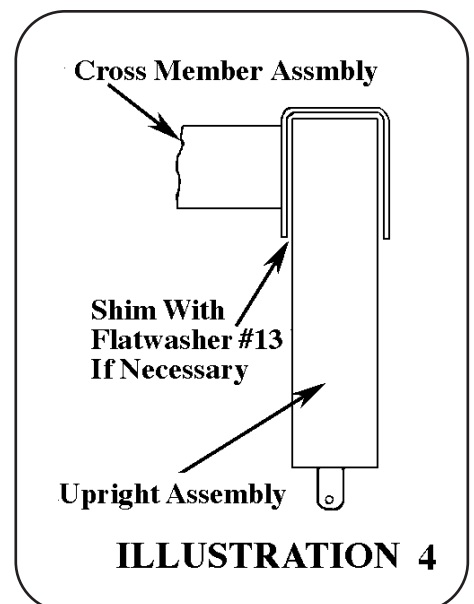

You are now ready to hook up your 5th wheel trailer.
See the "Trailer Hook Up Instructions" on the following pages.

TRAILER HOOK UP INSTRUCTIONS

FOLLOW THESE INSTRUCTIONS FOR EACH HOOK UP

1. Before connecting trailer to the hitch, the handle must be rotated clockwise and pulled out of head. It will hold in that position. If handle is out, jaw is open.
2. Adjust the trailer height so that the king pin plate is approximately 1/2" below the 5th wheel plate on the hitch. The ramps leading into the king pin box will pick up the trailer as the truck backs under the trailer king pin.
3. Lower the tailgate on the truck. Be sure that the trailer wheels are properly blocked, front and rear.
4. Carefully back the truck under the trailer so that the 2" king pin will engage fully into the hitch head and actuate the lock jaw. The jaw will have pivoted around the king pin into the closed position.
- 4a. Look at the indicator located on the right forward surface of the hitch head assembly. When it is extending out of the housing, the king pin is fully seated. See Illustration 5.
- 4b. Look at the jaw to be certain it is closed and that the handle is in as far as it will go. The small pin on the handle must be extending up through the slot in the head and the handle must be hanging down as shown on Illustration 6.

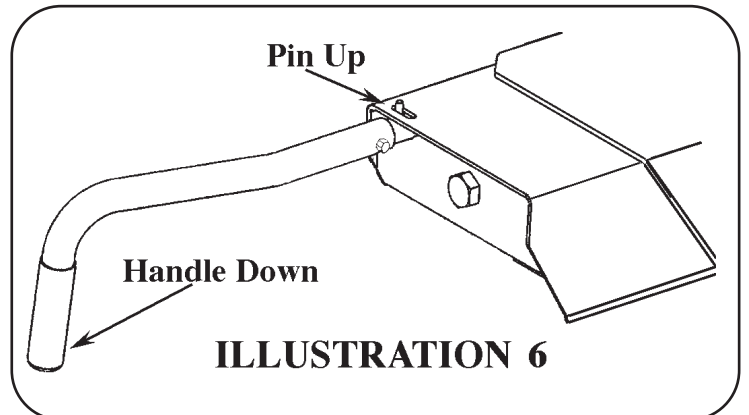
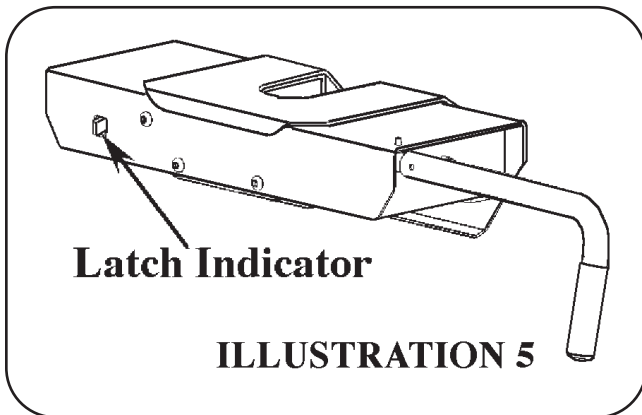

5. Connect the wiring harness from the trailer to the truck. Check trailer brakes and lights for correct operation. ***DO NOT*** raise the trailer jacks at this time.
6. With trailer jacks still down, apply trailer brakes alone and try to slowly pull forward with truck. This will double check that the king pin is locked into the 5th wheel assembly. The trailer brakes should keep the truck from moving forward if the hitch is locked correctly. Double check this operation.
7. Raise the trailer jacks to their retracted storage position. Remove the blocks from the front and rear of the trailer wheels.
8. Check between the bottom of the trailer overhang and the top of the truck bed for adequate clearance. Should be approximately 6".

TRAILER DISCONNECT INSTRUCTIONS

1. Block the front and rear of the trailer wheels. Disconnect the wiring harness from the truck.
2. Set the trailer jacks so that most, but not all, of the trailer load is off the hitch.
3. Rotate handle clockwise, so pin clears slot in head. Pull the handle out and continue rotating handle clockwise. This holds the jaw in the open position.
4. Drive the truck slowly forward and out from under the trailer

SERVICE AND MAINTENANCE INSTRUCTIONS

Lubricate all points on 5th wheel assembly as noted on illustrations below. Use heavy wheel bearing grease at all locations.

Keep internal jaw locking parts in head assembly well lubricated with a heavy wheel bearing grease for continued smooth operation.

The latch handle should be lubricated so that it will continue to move smoothly and easily.

Grease pivot pin using zerk fitting on plate end of pin,

Check for tightness of all assembly bolts. Re-tighten if necessary. Tighten 1/2-13 bolts to 75 ft. lbs. torque and 3/4-10 bolts to 260 ft. lbs. torque.

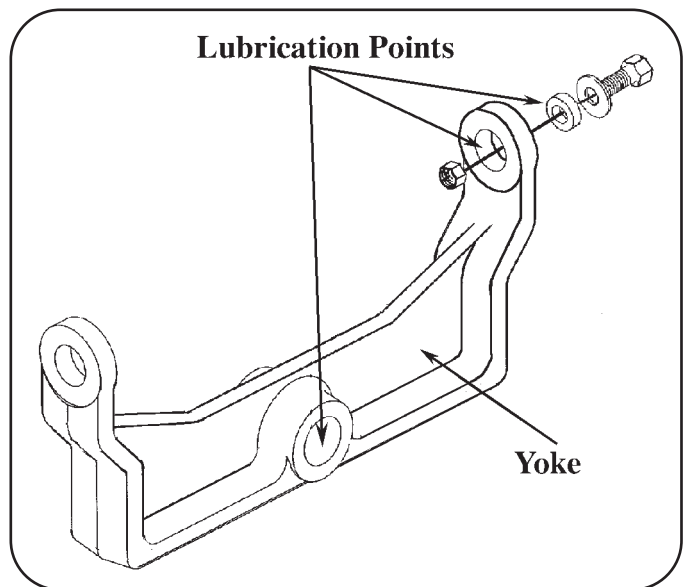
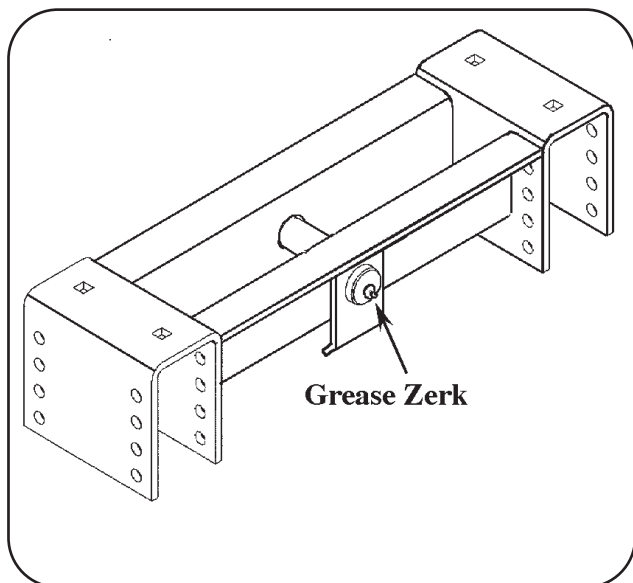
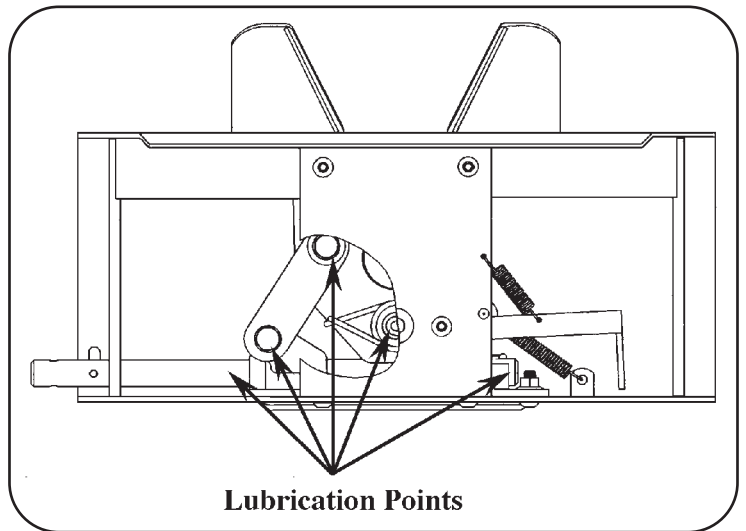

*Periodically check the moving parts inside the head assembly. If any one of them shows wear or damage, it should be replaced. Follow the illustrations below to replace parts in the head assembly.

REPLACEMENT PARTS LIST

Refer to Illustrations for locations of parts

| Part | Description | Quantity |
|------|---------------------------------|----------|
| 1. | 2610-05 Hitch Housing | (1) |
| 2. | 2603-04 Jaw Assembly | (1) |
| 3. | 3482-08 Torsion Spring | (1) |
| 4. | 2601-05 Connecting Link | (1) |
| 5. | 3279-03 Slide Bracket Bushing | (1) |
| 6. | 2581-09 Sliding Latch Assembly | (1) |
| 7. | 1501-06 Tension Spring | (2) |
| 8. | 2545-08 Yoke | (1) |
| 9. | 1374-04 Yoke Bushing | (2) |
| 10. | 2184-03 3/8-16 Button Head Bolt | (6) |
| 11. | 3491-02 1/2 Tooth Lockwasher | (2) |
| 12. | 1837-03 1/2-13 x 1-3/4 Hex Bolt | (1) |

| Part | Description | Quantity |
|------|---------------------------------|----------|
| 13. | 1846-09 1/2 Flatwasher | (2) |
| 14. | 2300-07 3/8 Conical Washer | (1) |
| 15. | 1828-03 1/2-13 Flange Locknut | (1) |
| 16. | 3626-03 1/2-13 x 1-1/4 Hex Bolt | (1) |
| 17. | 1428-03 3/4-10 x 2-1/2 Hex Bolt | (2) |
| 18. | 1850-06 3/4 Flatwasher | (2) |
| 19. | 1889-03 3/4-10 Hex Locknut | (2) |
| 20. | 4147-03 3/8-16 x 7/8 Hex Bolt | (1) |
| 21. | 2283-05 3/8-16 Locknut | (2) |
| 22. | 1950-02 3/8-16 Flange Locknut | (4) |
| 23. | 2619-09 Bottom Plate | (1) |
| 24. | 2602-02 Indicator Lever | (1) |

